

Idea of the KOBO technology

by

A. Korbel & W. Bochniak, AGH University of Science and Technology, Cracow

Many years studies on the phenomena of plastic flow and accompanying structural effects, proved that it is practically possible to highly limit the strain hardening of deformed metals as well as to control the final structure and properties of the products. They led to a new forming technology, called the KOBO method, which can be used during extrusion, forging, rolling or drawing (Fig. 1), and allows to the high efficient, low energy consuming deformation and formation of ultrafine grained structure.

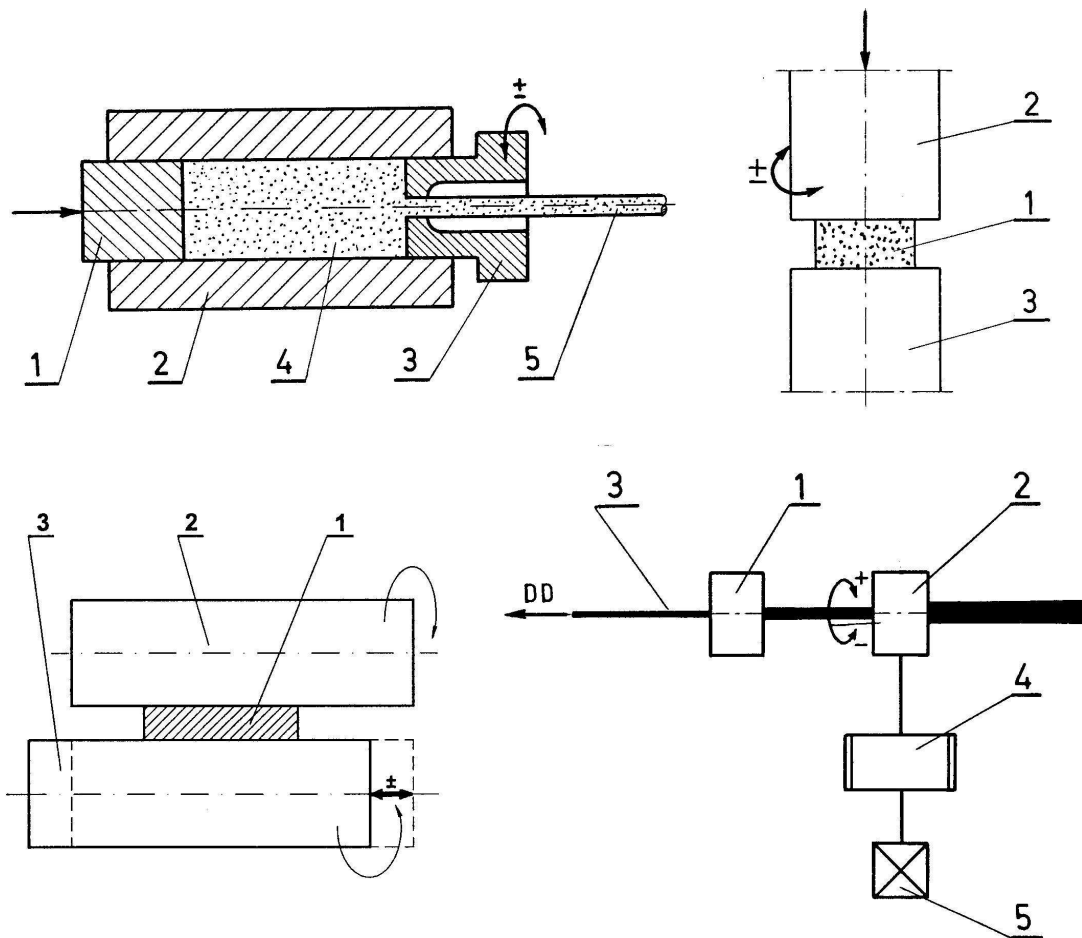

Figure 1. Schematic representation of some technical solutions of KOBO metal forming under conditions of cyclically changed loading scheme (the KOBO method); extrusion (1-punch, 2-container, 3-reversibly rotating die, 4-ingot, 5-product), forging (1-workpiece, 2-reversibly rotating punch, 3-stationary die), rolling (1-workpiece, 2-stationary roll, 3-reversibly shifting roll), drawing (1-stationary die, 2-reversibly rotating die, 3- wire, 4-gearbox, 5-motor).

The KOBO method consists in external induction in the metal of intensively localized plastic flow in the shear bands by the changes of the strain path as a result of the additional, cyclic reversible rotation of the shaping tools (changes of the loading scheme).